

# **Aneuvus Tech. Portable Bench**

## **Final Proposal**

**Hunter Daniel  
Katherine Riffle  
Kenyon Rowley**

**2019-2020**



**Project Sponsor: Aneuvus Tech.  
Faculty Advisor: Dr. Becker  
Instructor: Dr. Oman**

## **DISCLAIMER**

This report was prepared by students as part of a university course requirement. While considerable effort has been put into the project, it is not the work of licensed engineers and has not undergone the extensive verification that is common in the profession. The information, data, conclusions, and content of this report should not be relied upon or utilized without thorough, independent testing and verification. University faculty members may have been associated with this project as advisors, sponsors, or course instructors, but as such they are not responsible for the accuracy of results or conclusions.

## **EXECUTIVE SUMMARY**

Aneuvvas Tech. is a company located in Flagstaff, AZ. ATI develops microcatheter-based medical devices to treat aneurysms and other vascular defects. The company's mission is to improve health care through minimally invasive treatments to blood vessels. The team is tasked with designing, building, and testing a portable medical bench that can be used to safely transport the devices used in research. The bench must be large enough to hold all devices required in the research process, be equipped for stable transport through connecting buildings, and be compatible with fluoroscopic imaging. Among these requirements, the bench must also have a waterproof countertop designed for spill prevention. Be able to withstand the load of a 75lb hood and have storage space added below the tabletop. This project was given a budget of \$1000. The project is divided into three parts: tabletop design, storage, and shock absorption. Multiple design solutions address the customer needs, including raised platforms on the side of the table, drainage, flanges to secure medical devices, and zip ties. After evaluation of these designs and consideration of customer preference, the final design of the tabletop included a single handle for transport, an incline for spill direction, and a polycarbonate workspace for x-ray compatibility. Wood was determined to be the material used for the majority of the tabletop. Going forward, the team needs to decide how the wood will be made waterproof to prevent the tabletop from breaking down due to spills. The storage design went through an evaluation process as well. The two concepts being considered were a U-shape design and implementing drawers. The team decided to go with both concepts and combine them into a single design. This would allow for maximum storage space without taking up room needed for the medical devices. In the case of shock absorption, three different concepts were evaluated. First, the team considered using MRF dampers on the wheel. This, however, proved to be too expensive for the need. Then the team looked into using pneumatic tires. The client suggested that a different tire should be used considering the pneumatic tires could go flat. Finally, the team went with non-flat wheelbarrow tires for the wheels. Currently, the team has completed the CAD design and has created a rough prototype. Moving forward the team will need to refine the materials needed for the project and create a functioning prototype.

# TABLE OF CONTENTS

Contents

## **DISCLAIMER**

## **EXECUTIVE SUMMARY**

## **TABLE OF CONTENTS**

### **I BACKGROUND I**

1.1 Introduction

1.2 Project Description

### **II REQUIREMENTS II**

2.1 Customer Requirements (CRs)

2.2 Engineering Requirements (ERs)

2.3 Functional Decomposition

2.3.1 Black Box Model

2.3.2 Functional Model/Work-Process Diagram/Hierarchical Task Analysis

2.4 House of Quality (HoQ)

2.5 Standards, Codes, and Regulations

### **III Testing Procedures (TPs) III**

3.1 Testing Procedure 1: Shock Absorption

3.1.1 Testing Procedure 1: Objective

3.1.2 Testing Procedure 1: Resources Required

3.1.3 Testing Procedure 1: Schedule

3.2 Testing Procedure 2: Safety

3.2.1 Testing Procedure 2: Objective

3.2.2 Testing Procedure 2: Resources Required

3.2.3 Testing Procedure 2: Schedule

3.3 Testing Procedure 3: Maneuverability

3.3.1 Testing Procedure 3: Objective

3.3.2 Testing Procedure 3: Resources Required

3.3.3 Testing Procedure 3: Schedule

3.4 Testing Procedure 4: Tabletop/Workspace

3.4.1 Testing Procedure 4: Objective

3.4.2 Testing Procedure 4: Resources Required

3.4.3 Testing Procedure 4: Schedule

3.5 Testing Procedure 5: Legs/Frame

3.5.1 Testing Procedure 5: Objective

3.5.2 Testing Procedure 5: Resources Required

3.5.3 Testing Procedure 5: Schedule

### **IV Risk Analysis and Mitigation IV**

4.1 Critical Failures

4.1.1 Potential Critical Failure 1: Polyurethane Wheel

4.1.2 Potential Critical Failure 2: Raised Platform

4.1.3 Potential Critical Failure 3: Zip Ties

4.1.4 Potential Critical Failure 4: Drainage

4.1.5 Potential Critical Failure 5: U-Shape

4.1.6 Potential Critical Failure 6: Drawers

4.1.7 Potential Critical Failure 7: Single Handle

4.1.8 Potential Critical Failure 8: Inclined Tabletop

4.1.9 Potential Critical Failure 9: Polycarbonate Workspace

4.1.10 Potential Critical Failure 10: Polycarbonate Workspace

4.2 Risks and Trade-offs Analysis

**V DESIGN SELECTED – First Semester V**

5.1 Design Description

5.2 Implementation Plan

**VI CONCLUSIONS VI**

**VIII APPENDICES VIII**

8.1 Appendix A: Descriptive Title

8.2 Appendix B: Descriptive Title

## **I BACKGROUND I**

### 1.1: Introduction

The Aneuvus Tech. project tasks the team with the design and construction of a portable medical bench. The bench's main functional requirements include transporting the medical devices used in the treatment of aneurysms, compatible with fluoroscopic imaging, and shock absorption wheels. The project's client wishes to replace the existing bench design with one that has more functions and makes the treatment process easier and more effective. Upon completion of the bench, the project's client will be able to transport medical devices in a safer and more effective manner. With the added requirements, the new design will offer more functionality than the previous. Although there is an existing bench design that is able to transport medical devices, an improvement is much needed, as it is not x-ray compatible and is only used for storage and transport. With the addition of the concepts being considered in this project, the new design will be able to do the same functions as the old but will improve on these functions and add to them. The new design will secure the devices, be x-ray compatible, be constructed with shock absorbing tires, designed to prevent spills, and add storage space. These improvements will make the job of the project's client easier and allow for more effective treatment for patients.

### 1.2: Project Description

The project's sponsor provided the following quote:  
"The scope of this project is to design, build, and test a portable bench that can be used with the company's delicate blood flow model of the brain. The bench must be large enough to contain the delicate experimental setup, allowing for stable transport of the setup to adjacent buildings, and be compatible with fluoroscopic imaging of the blood flow model through the bench surface."

## II REQUIREMENTS II

The following sections detail the customer requirements, gathered from the client description along with meetings with the client, and their transformation into engineering requirements for evaluation of the bench. A functional decomposition model is used to evaluate generated concepts, along with black box models of all critical components to find out what would go in and what would come out of critical subsystems. A House of Quality (HOQ) diagram shows how the customer requirements became engineering requirements and are evaluated based on weights of the customer requirements. Finally, standards, codes, and regulations are stated and how they apply to the project.

### 2.1: Customer Requirements (CRs)

*Table 1: Customer Requirements*

<b><u>Customer Requirement</u></b>	<b><u>Weight (9/3/1)</u></b>
Durable and Robust Design	9
Reliable Design	9
Safe to Operate	9
Maneuverability	9
Cost within Budget	3
Aesthetically Pleasing	1
Multipurpose Design	3
Lightweight Design	3
Shock Absorption	9
Adequate Storage Space	3

The Customer Requirements are rated on a 9/3/1 scale, as shown in the table above. A nine would mean very important, a three would mean moderately important, and a one would mean not so important to the client. For durable and robust design, the portable bench must be easily transported inside and outside of buildings and withstand the stresses of going over bumps and obstacles, while supporting the devices and clean-room hood. The design must be reliable in performance of all its basic needs. It must be safe to operate. The bench will be transporting over 100 lbs. of equipment and must be safe to transport. It must maneuver over terrains associated with NAU campus. The cost of the device must be within a budget of \$1000, including everything associated with the project. Aesthetic is for display purposes only and not a big concern for the project. The design must allow for multipurpose use as a desk. It must be

lightweight, to be transported by one person with ease. The design must be shock absorbing, for transportation of bench across parts of campus. There must be adequate storage space for transporting all the necessary accessories.

## 2.2: Engineering Requirements (ERs)

*Table 2: Engineering Requirements*

<b><u>Engineering Requirement</u></b>	<b><u>Units</u></b>	<b><u>Target Value</u></b>	<b><u>Tolerance</u></b>
Cost	\$	1000	+/- 100
Weight	lb	50	+/- 10
Fitting through doorway	ft <sup>3</sup>	40	+/- 5
Yield Strength	psi	10	+/- 5
Effective shock absorption	in/s <sup>2</sup>	5	+/- 5
Deflection	in	0.25	+/- .05
Thickness	in	1	+/- 0.5
Height	in	36	+/- 1
Strain	in/in	0	+/- 1
Temperature resistance	°F	50	+/- 50

Shown in the above table is all Engineering Requirements with their respective target values and tolerances. To achieve cost effectiveness, money must be meticulously spent to get the best performing design. The target value is \$1000 with a tolerance of \$100 that was discussed with the client. Weight of the device must be as low as possible, to easily transport the bench with ease. This has a value of 50 lbs. with a tolerance of 10 lbs. because the bench should be as light as possible. It must fit through doorways with a minimum volume, warranting a target value of 40 ft<sup>3</sup> with a tolerance of 5 ft<sup>3</sup>. With dimensions calculated, it should be about 40 ft<sup>3</sup> to comfortably fit through doors and other places. The yield strength must be high enough to withstand loads on the device. The target value is 10 psi with a tolerance of 5 psi. This value is derived from the 100 lbs of weight the table holds, with the dimensions of the tabletop. The wheels must have effective shock absorption. This was a change made to the engineering requirements from changing from using a spring for shock absorption to using a different type of tires, based on client preference. This will be measured in acceleration. Deflection of the tabletop must be at a minimum.  $0.25 \pm 0.05$  in should be used for minimum deflection considering the sensitive experimental setup. The thickness must be minimal, while maintaining strength, for minimal interference with the x-ray procedure.  $1 \pm 0.5$  in is adequate for being x-ray compatible. The height of the device must be

small enough to fit the hood on top, while also fitting through doorways and into the secondary hood. The target height is 36 in with a tolerance of 0 in. This is because 36 in is height of the hood and doorways. The strain on the legs and springs must be minimal, so the target is  $0 \pm 5$  in/in. The temperature resistance of the tabletop must resist deformation, so the target resistance of  $50 \pm 50$  °F to account for the possible cold temperatures in Flagstaff. This is also due to estimates in operating temperature of the devices on top of the table, specifically the pump and battery.

### 2.3: Functional Decomposition

#### 2.3.1: Black Box Model

The three black box models presented below represent three models for the main subsystems of the tabletop, the tabletop, the storage, and shock absorption.

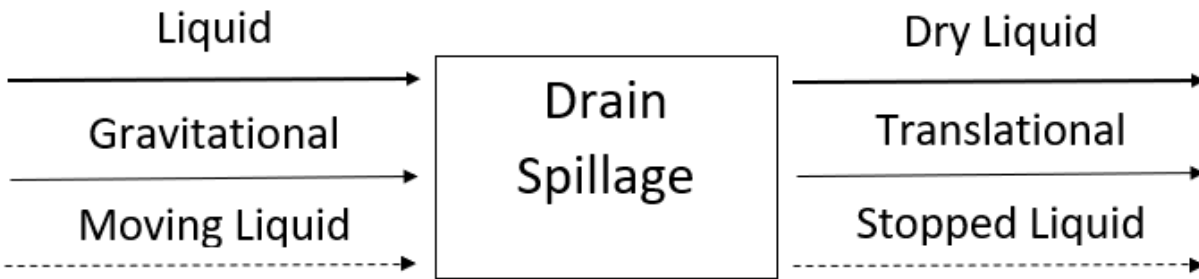

*Figure 1: Black Box Model, Tabletop*

The figure above shows the black box model for the tabletop. This helps the team in being able to understand how to attack the problem of spillage on the tabletop. This was addressed by having the tabletop have a decline in order to have the spills that incur move towards the front of the table.



*Figure 2: Black Box Model, Storage*

The figure above shows the black box model for the storage. This helps the team in figuring out the best ways to store materials. The team has decided to go with a hybrid design for storage with U-shaped but including a drawer.



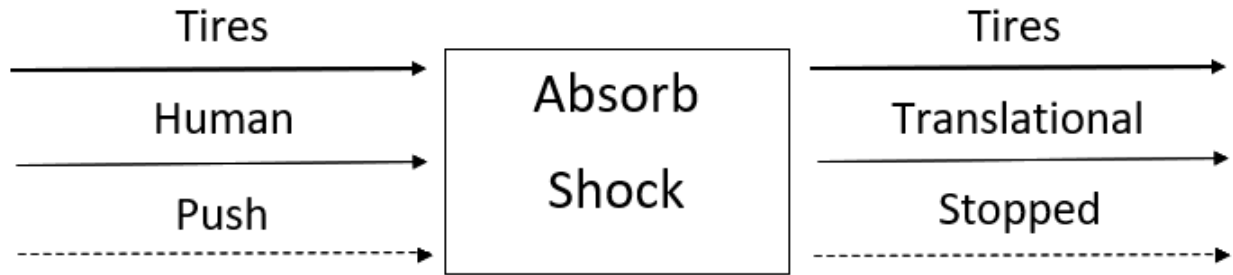

Figure 3: Black Box Model, Shock Absorption

The figure above shows the black box model for the shock absorbing tires. This helps the team in visualizing what the shock absorption will demand. The team has decided to go with a sort of a wheelbarrow tire that does not require air to be pumped into it. This will create enough absorption while also being as maintenance free as possible.

2.3.2: Functional Model/Work-Process Diagram/Hierarchical Task Analysis

The team used a work-process diagram to evaluate the generated concepts. This model organizes the many different concepts. The team tried to evaluate each concept through the customer and engineering requirements as well as the client's preference. Similar to the black box model, the work-process model is separated into three parts.

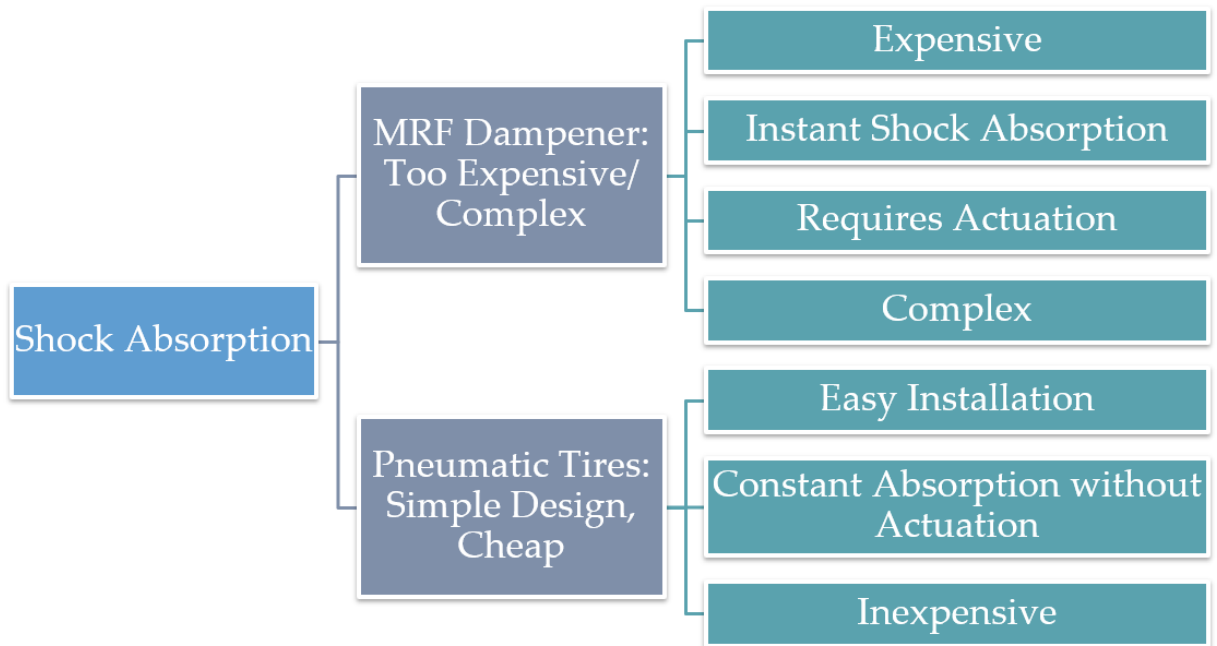

Figure 4: Work-Process Model, Wheels

Figure 4 shows the work-process model constructed for the shock absorption concept. In the model, two designs are being evaluated. One being the MRF damper and the other is the pneumatic tire design. As the model shows, the damper offers a high shock absorption but is expensive, requires actuation, and is complex. The pneumatic tire design is easy to install, offers

constant shock absorption without actuation, and is cheap. The team is going with the design of pneumatic tires due to client preference, reliability, and cheap design.

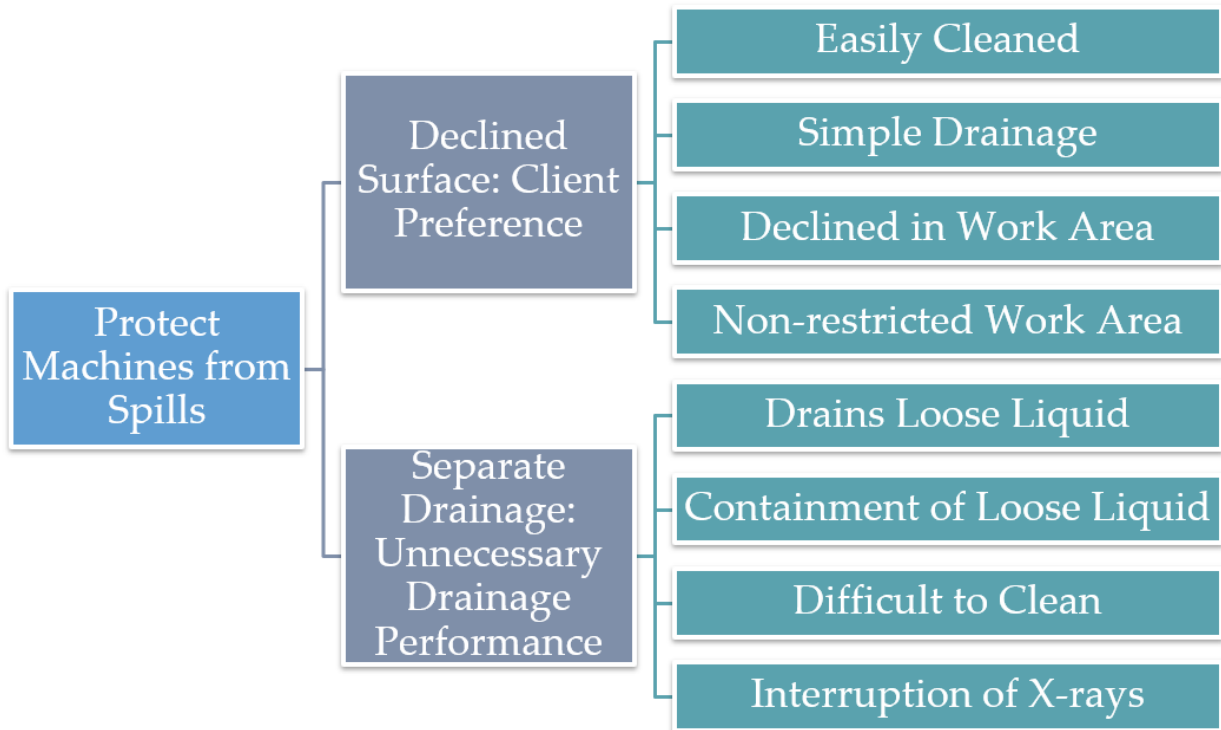

Figure 5: Work-Process Model, Tabletop

Figure 5 details the work-process model constructed for the tabletop. This model is comparing the concepts of a declined surface and having separate drainage in order to protect medical devices from spills. The declined surface was a recent addition to the functional decomposition model due to client preference, and simplicity of drainage and cleaning. Drainage is effective in removing excess fluid but is difficult to clean. The team is going with the design of a declined tabletop surface because of this client preference.

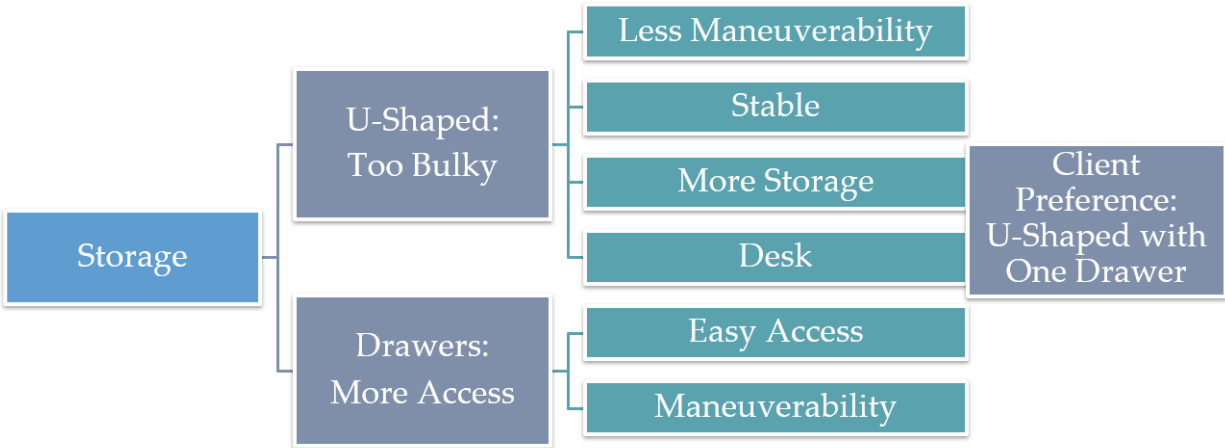

Figure 6: Work-Process Model, Storage

Figure 6 illustrates the work-process model used for the storage designs. The two designs being evaluated are U-shaped design and drawers. The U-shape design is less maneuverable, but is stable and offers more space. The drawers are more easy to access. This was updated to reflect client desire to have parts of both designs included. Due to this client preference, the team is going with a hybrid of both designs, having U-shaped storage with a drawer on one side of the storage itself.

#### 2.4: House of Quality (HoQ)

The following Figure 1 is the HoQ diagram for the portable bench. This figure calculated what design criteria were the most important to consider when designing the bench. The three most important engineering requirements from the HoQ calculations are weight, deflection, and fitting through doorways (volume). These agree with the customer requirements and client meetings.

Customer Requirement	Weight	Engineering Requirement	Cost(\$)	Weight(lb)	Fitting through doorway(ft* 3)	Yield Strength(psi)	Effective Shock Absorption(a)	Deflection(in)	Thickness(in)	Height(in)	Strain(in/in)	Temperature (°F)
1. Durable and robust design	9		3			3	3	9				1
2. Reliable design	9		3	3	3	3	3			3	3	1
3. Safe to operate	9		1	3	1	3		3		3	3	9
4. Maneuverability	9		1	9	9				1	3		
5. Cost within budget	3		9	3	1				1			1
6. Aesthetically pleasing	1		1									
7. Multipurpose design	3		3									
8. Lightweight design	3		3	9	3				3	3		
9. Shock absorbing wheels	9										9	
10. Adequate storage space	3											
<b>Absolute Technical Importance (ATI)</b>			118	171	129	81	54	135	21	90	57	99
<b>Relative Technical Importance (RTI)</b>			0.12	0.18	0.14	0.08	0.06	0.14	0.02	0.09	0.06	0.10
<b>Target ER values</b>			1,000	50	40	10	5	0.25	1	36	0	50
<b>Tolerances of Ers</b>			100	10	5	5	5	0.05	0.5	1	1	50
<b>Testing Procedure(TP#)</b>			n/a	1	1	2	3	2	1	1	2	4

Figure 7: House of Quality Diagram for Portable Bench

## 2.5: Standards, Codes, and Regulations

The following table represents standards of practice and codes as applied to designing the portable bench.

Table 3: Standards of Practice as Applied to this Project

<u>Standard Number or Code</u>	<u>Title of Standard</u>	<u>How it applies to Project</u>
ASME Y14.5-2009	Dimensioning and Tolerancing	Helps with making drawings of parts to be manufactured with GD&T specifications for manufacturing.
ASCE 37-02	Design Loads on Structures	Provides guidance on designing for loads on top of the tabletop
ASCE 7-05	Minimum Design Loads on Structures	Shows minimum design loads for structures including floors, which will be modeled with the tabletop.
ANSI/AAMI HE 74:2001	Human Factors Design Process for Medical Devices	Will help with how the medical devices will interact with the user and the bench in a safe manner.

### **III Testing Procedures (TPs) III**

The testable Customer Requirements, from Table 1, are that the cart is (1) durable and robust, (2) reliable, (3) safe, (4) maneuverable, and (9) shock absorbing. The cart's (1) durability and (2) reliability will be tested through the Engineering Requirements of yield strength, deflection, and strain. The cart's (4) maneuverability will be tested through the Engineering Requirement fitting through doorways. The cart's (3) safety will be tested through the Engineering Requirement temperature, and through making sure every edge is not sharp. The cart's (9) shock absorbency, both a Customer Requirement and an Engineering Requirement, will be tested both with and without the clean room hood. The remaining Customer Requirements (5) cost, (6) aesthetic, (7) multipurpose, (8) lightweight, (10) storage space, and the corresponding Engineering Requirements are not ones that can be tested, but are instead requirements that can be checked off for whether it meets the requirements.

#### 3.1 Testing Procedure: Shock Absorption

The test will be to maneuver the cart with specifically applied predetermined forces as measured with tools from the mechanics of materials lab. These forces will be applied to the cart on the paths it will take during use, and over the obstacles present in the clean-room facilities. The forces are applied to the cart with the clean-room hood and without it. This will test the shock absorption of the tires. The testing procedure is initially done with substitute medical devices. The shock absorption effectiveness will be determined based off how well the wheels dampen the contact the bench makes with obstructions in its path.

##### 3.1.1: Objective:

The loads placed on the bench for testing will be the weight of the medical devices needed to be transported within the Wettaw building. The effectiveness of the wheels will be determined by using a dynamometer. Based off the readings from the dynamometer, the wheels will be evaluated relative to engineering requirements 2, 3, 4, and 9. If it is determined that the wheels perform within the conditions of these requirements, the wheels will have passed the testing procedures.

##### 3.1.2: Resources Required

The resources needed to perform the testing procedures of the wheels are minimal. The team needs to obtain access to the medical devices that will be transported by the bench to accurately simulate the loads. A dynamometer is needed to measure the ability of the wheels to absorb obstructions while in transport. A team member will perform the test by pushing the bench through the building on the path it will take for treatments. The location of the test will be the Wettaw building to make the test as accurate a simulation as possible.

##### 3.1.3: Schedule

Before beginning testing of the wheels, the team needs to wait for the ordered devices to be delivered. After gaining access to the medical devices the team will need to acquire a dynamometer. Then the team will then need to schedule a time to meet with Dr. Becker in the Wettaw building to perform the test. The devices are scheduled to be delivered by November 18th and testing can begin shortly after that.

#### 3.2: Testing Procedure: Safety

Part of the safety requirement is achieved through the other tests, such as making sure the apparatus will not tip over, but specific to safety is testing the temperature requirements. Test temperatures will be determined and applied to the apparatus at appropriate locations to ensure the apparatus will not warp dangerously when those environments are applied. Higher temperature can be applied to the generator storage area and the tabletop where the hot plate will be used. Lower temperatures should be applied to every aspect of the apparatus. This can be tested on each aspect of the cart during construction, on each of the pieces before they are used and on each of the cart's parts before they are added to the full apparatus, and finally applied to the full apparatus. Lastly, for safety every sharp edge should be sanded or otherwise smoothed.

### 3.2.1: Objective

The procedure tests the apparatus temperature resistance. This is important to the project so that critical failure does not occur when the hot plate and generator are used on the cart, and when the cart is brought outside into Flagstaff for transportation. Appropriate temperatures, high and low, are determined to test the cart's temperature resistance. The lower temperature will be tested for a limited amount of time, but the higher temperatures will be applied to the afflicted areas to raise those areas to a temperature respective of an indefinite exposure to expected temperatures. These temperature tests will be done on the raw materials before construction, on each of the parts after individual construction, and on the final constructed cart.

### 3.2.2: Resources Required

For the colder temperatures, the parts can be placed in freezers of varying sizes. For the hot temperatures applied at more finite locations, a hot plate can be used. Protective safety gear should be worn by the person(s) completing the high temperature testing. The tests will be on materials, parts, and the final cart, so these are required at their respective points in the construction schedule.

### 3.2.3: Schedule

The testing procedure should occur on the materials before construction begins, when the materials and parts have been collected. The test should also occur after materials have been combined, to test their connections in the appropriate environments. Lastly, the tests will occur after the cart has been constructed, before testing the actual medical devices on the cart.

## 3.3: Testing Procedure: Maneuverability

The test will be to maneuver the cart apparatus through its destined paths using substitute medical devices before using the real ones. The requirements of these tests are maneuverability, height, and fitting through doorways. This test can only be done after the cart has been constructed, but the design dimensions used during construction should incorporate measured dimensions from the existing parts of the full cart.

### 3.3.1: Objective

This procedure tests the apparatus maneuverability through testing its height and its ability to fit through doorways. Preliminary and comprehensive design dimensions are computed well before construction begins, and incorporates actual heights of the doorways, elevators, and devices. The tests will be run by one person maneuvering the constructed apparatus along the transportation path the final cart will take. This is an important aspect of the project to test so that the cart can easily be used for its intended purposes without disrupting the medical devices.

### 3.3.2: Resources Required

The resources required will be one person maneuvering and testing apparatus, while another two people observe transportation and aid in set-up as a research assistant might do. The testing procedure will first be done with substitute medical devices that have identical dimensions. It is imperative that the test additionally be done with the actual medical devices before the cart can be considered successful.

### 3.3.3: Schedule

The testing procedure can only be done after the cart has been constructed, but its specific design dimensions incorporating pre-constructed aspects like the clean-room hood, the filter, and the tires will be appropriately designed and applied.

## 3.4: Testing Procedure: Tabletop/Workspace

The tabletop and workspace are tested for strength, strain, and deflection. The test will be done on SolidWorks computer modeling, both before construction and after construction of the frame with an updated computer model. The requirements of these tests are stress, strain, deflection, durability, and reliability. Lastly, the points of interest determined from the modelling will be physically tested on the polycarbonate workspace to test the seal strength and rigidity.

### 3.4.1: Objective

The tabletop and workspace must be tested for durability and reliability. The tabletop and workspace will be tested for deflection, strength, and strain. The test will determine the amount of force necessary to fracture the apparatus, and the flexibility and level of deflection responding to reasonable forces. The team can then determine if the fatal amount of force is achievable in any reasonable environment, and if the amount of deflection active from reasonable forces should be addressed. These forces will not appear as often during transportation, but more often during set-up of the apparatus. The test will be run through computer modelling of the apparatus.

### 3.4.2: Resources Required

The apparatus must be constructed and the specifics of how each piece is cut and fits together recorded meticulously so that the computer model can be updated to match before the tests can be accurate. Tests preliminary to the apparatus construction would rely on a more ideal model. The tests will be done through SolidWorks software testing models. Additional testing of the polycarbonate workspace seal will be tested through physically applying force to points of interest on the final polycarbonate. These forces can be measured with tools used in the mechanics of materials lab.

### 3.4.3: Schedule

The tabletop and workspace must be constructed before the 3D SolidWorks tests can be run, providing a more accurate computer model. Preliminary 3D model testing is required so that any large changes can be made before construction. The preliminary design and its testing would be completed before construction begins, and the updated model testing would be completed after construction.

## 3.5: Testing Procedure: Legs/Frame

The legs and frame are tested for strength, strain, and tip. The test will be done on SolidWorks computer modeling, both before construction and after construction of the frame with an updated computer model. The requirements of these tests are stress, strain, durability, and reliability.

#### 3.5.1: Objective

The legs and frame must be tested for durability and reliability. The legs and frame, including the clean-room hood frame, will be tested for strength and strain. The test will determine the amount of force necessary to tip the top-heavy, but wide-framed, apparatus and the amount of force necessary to damage the frame. The team can then determine if this amount of force is achievable in any reasonable environment. This particular aspect must be tested because if any of these failures occur during transport, the expensive medical devices are compromised. The test will be run through computer modelling of the apparatus.

#### 3.5.2: Resources Required

The apparatus must be constructed and the specifics of how each piece fits together and is welded together recorded meticulously so that the computer model can be updated to match before the tests can be accurate. Tests preliminary to the apparatus construction would rely on a more ideal model. The tests will be done through SolidWorks software testing models.

#### 3.5.3: Schedule

The frame must be constructed before the 3D SolidWorks tests can be run, providing a more accurate computer model. Preliminary 3D model testing is also required, however, so that any large changes can be made before construction. The preliminary design and its testing would be completed before construction begins, and the updated model testing would be completed after construction.



## IV Risk Analysis and Mitigation IV

Medical Bench		Team B5				Page No. of			
Tabletop						FMEA Number			
Storage						Date			
Wheels									
Part # and Functions	Potential Failure Mode	Potential Effect(s) of Failure	Severity (S)	Potential Causes and Mechanisms of Failure	Occurance (O)	Current Design Controls Test	Detection (D)	RPN	Recommended Action
Polyurethane wheel	Corrosive wear	Not able to transport	9	Over stressing	5	Wear test in field	5	225	Look into different tire material
Raised platform	Direct chemical attack	Spills ocuring	7	Poor maintenance	7	Chemical test	5	245	Material selction
Zipties	Deformatin wear	Devices not held in place	8	Over stressing	7	Stress testing	6	336	Thickness values
Drainage	Direct chemical attack	Inproper disposal of waste	7	Chemical wear	6	Chemical test	5	210	Material selction
U-shape	Impact wear	Broken storage	6	Impact loading	6	Impcat test	6	216	Cushion design
Drawers	Impact wear	Unable to use storage	6	Impcat loading	6	Impcat test	6	216	Cushion design

*Figure 8: FMEA Analysis*

Three subsystems were analyzed for potential failure in the design. These subsystems are the tabletop, storage, and wheels design. Within the tabletop design, the raised platform, drainage, and zip tie concepts were considered. The storage design included the U-shape and drawer concepts. The wheels design considered the polyurethane concept. The ranking system was based on a 1-9 numerical scale. The scaling was evaluated by 1-2 being considered very low occurrence, 3-4 slightly likely, 4-5 likely, 6-7 above average, and 8-9 very concerning.

### 4.1: Critical Failures

#### 4.1.1: Potential Critical Failure 1: Polyurethane Wheel

The polyurethane wheel was introduced through client preference. It was introduced due to it having a non-flat design. The potential failure of the tire was determined to be corrosive wear. The potential effects of this failure include not being able to transport the bench. The severity of this potential failure was ranked a 9. This failure can be mitigated by testing different tire material for a longer fatigue life.

#### 4.1.2: Potential Critical Failure 2: Raised Platform

The raised platform concept was designed to prevent spills. The potential failure occurs from direct chemical attack. The potential effect of failure would have spills occurring. The severity of this occurring was ranked as a 7. This failure could be mitigated through proper material selection that is compatible with the chemicals used in sanitation.

#### 4.1.3: Potential Critical Failure 3: Zip Ties

The zip tie concept was designed to secure the medical devices on the tabletop. The potential failure occurs from deformation wear of the zip ties rubbing against the tabletop material. The effects of this failure include the devices not held in place. The severity of this failure was ranked as an 8. This failure can be mitigated by increasing the thickness of the tabletop slit.

#### 4.1.3: Potential Critical Failure 4: Drainage

The potential failure occurs from direct chemical attack. The effect of this failure is an improper disposal of waste. The severity of this failure was ranked as a 7. This failure could be mitigated through proper material selection that is compatible with the chemicals used in sanitation.

#### 4.1.5: Potential Critical Failure 5: U-Shape

The potential failure occurs from impact wear. The effect of failure is lack of use of storage. The severity was ranked a 6. This failure can be mitigated through adding a cushion design to the storage concept.

#### 4.1.6: Potential Critical Failure 6: Drawers

The drawer concept was introduced to maximize space for storage without taking away space for the medical devices being stored under the tabletop. The potential failure occurs from impact wear. The effects of this failure are lack of use of storage. The severity of this failure was ranked a 6. This failure can be mitigated through adding a cushion design to the storage concept.

#### 4.1.7: Potential Critical Failure 7: Single Handle

The single handle was introduced by the project's client as a preference. The potential failure occurs from corrosive wear. The potential effects of this failure are difficulty transporting the bench. The severity of this failure was ranked a 5. This failure can be mitigated by adding textured handles to the material of the handle.

#### 4.1.8: Potential Critical Failure 8: Inclined Tabletop

The inclined tabletop concept was designed to assist in directing spills. The potential failure occurs from direct chemical attack. The potential effects of this failure could cause spills to seep into the devices on the tabletop. The severity of this failure was ranked a 9. This failure could be mitigated through proper material selection that is compatible with the chemicals used in sanitation.

#### 4.1.9: Potential Critical Failure 9: Polycarbonate Workspace

Polycarbonate was used for the material of because it is x-ray compatible. The potential failure occurs from deformation wear. The potential effects of this failure could distort the x-ray imaging needed during treatment. The severity of this failure was ranked an 8. This failure could be mitigated by increasing the thickness of the material.

#### 4.1.10: Potential Critical Failure 10: Polycarbonate Workspace

The grooves were designed to hold the hood in place. The potential failure occurs from deformation wear. The potential effects of this failure could result in the hood not being secure. The severity of this failure was ranked a 7. This failure could be mitigated by increasing the thickness of the grooves to better support the weight of the hood.

### 4.2: Risks and Trade-offs Analysis

After conducting the failure analysis, the failures of highest concern affect the ability to transport the bench and to secure the medical devices being stored. These failures are the most severe due to the effects interfering with the projects top ranked customer requirements. In mitigating these failures, all can be addressed without taking away from the other. In narrowing in on the final design, the team compared the severity of each failure with the top ranked customer requirements to identify the crucial design changes needed.

## V DESIGN SELECTED – First Semester V

This section fully described the final determined design, comparing it to the design presented in the Preliminary Report. Client requests for this revision include increasing the tabletop length to six feet, employing a different type of shock absorbing tires, and providing storage specifications. The design is illustrated through SolidWorks 3D modelling, and through prototypes of some of the design's particular aspects. The final design is communicated by first describing the tabletop, storage, and shock absorption components, then presenting the design as a full assembly, to show how the components fit together with the table legs, and to explain aspect placement.

### 5.1: Design Description

#### Final Design: Tabletop

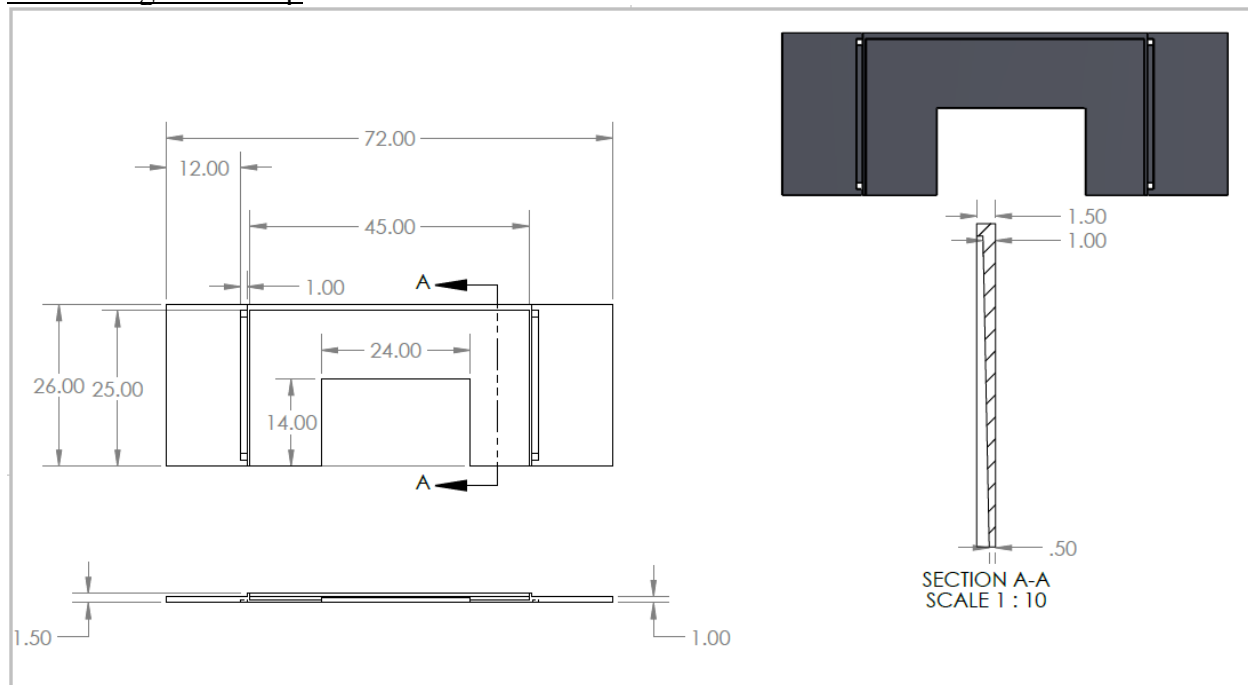

Figure 9: Final Tabletop SolidWorks Design

Figure 9 depicts the final design for the tabletop, with measurements in inches. The polycarbonate workspace is attached to the 14"x24" area in the center of the tabletop. This area corresponds to the clean-room hood workspace access. Polycarbonate does not span the entire tabletop because it is not sturdy enough to support devices or normal desktop live loads without movement. The deflection relies inversely on Young's Modulus, measuring elasticity, and the value of Polycarbonate is too low, around  $10^6$ psi, to allow for a low deflection at such a thin workspace. The workspace area may have to be reduced if, during testing, the polycarbonate is determined to be too flexible for its thickness. A different material is used for the rest of the tabletop because it should be a material that does not require reinforcements across the workspace area, to minimize x-ray videography/imaging interference. The tabletop is made 1.0" thick so that it does not interfere, geometrically, with the x-ray machine, which should reach as close to the top of the workspace through the thickness of the workspace as possible. This thickness has not

changed during past revisions. The 25"x45" workspace area in the middle of the tabletop is contained within the clean-room hood area. It features a tilt for liquid spill drainage as shown in Section Cut A-A of Figure 9. This differs from the prior revision, shown in Figure 9, which does not feature the tilt, and instead uses elevated platforms to protect the devices from spills. The tilt is 0.5" downward from the back of the workspace to the front of the workspace and was added as such per client request. The workspace also features a containing spill guard, protecting the clean-room hood grooves from spills, and containing spills from falling behind the cart. This was also featured in the previous revision. The clean-room hood grooves provide an area for the clean-room hood to be placed into. The clean-room hood will be removed or attached by two people, placing it down onto the table, per client instructions, and will not slide off of the table. This was made clear early in the process and has not changed during revisions. The last change to the tabletop from the prior revision is an increase in table length to 72", per client request. This length is added to either side of the workspace, keeping the clean-room hood centered on the tabletop.

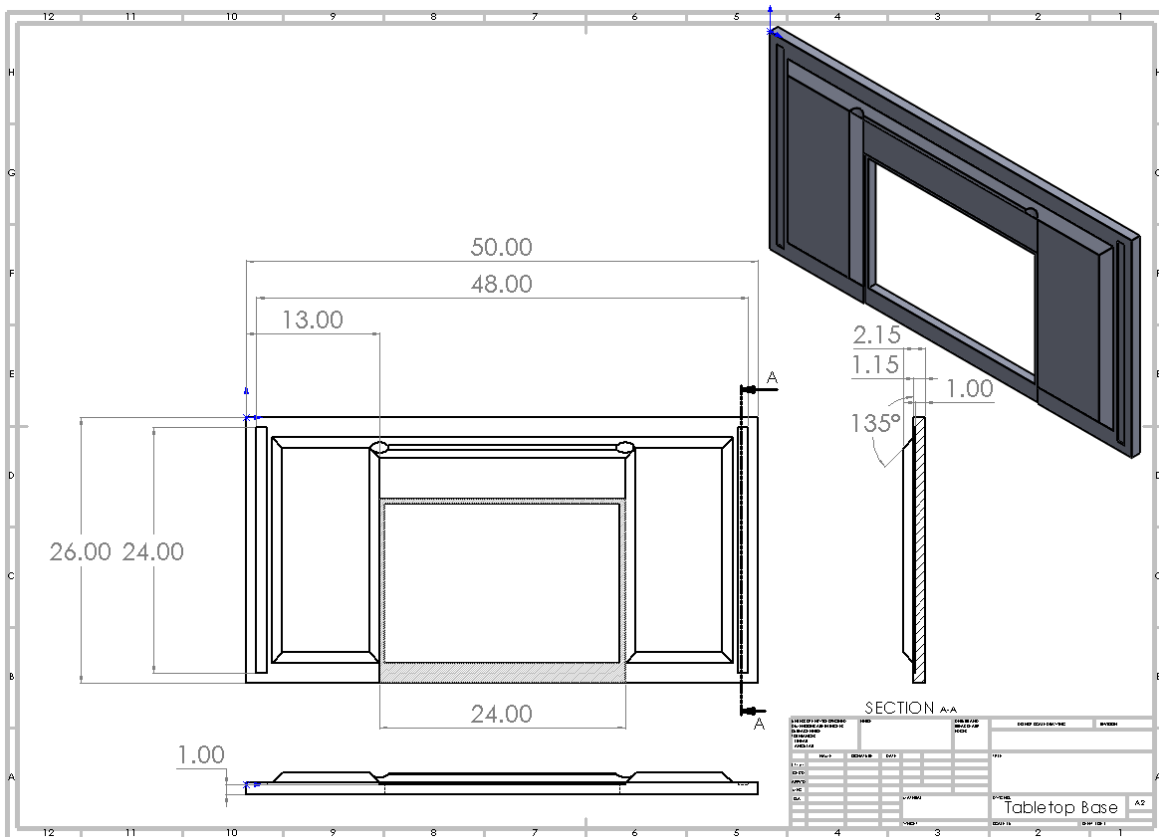

Figure 10: Preliminary Report Tabletop SolidWorks Design

The tabletop prototype, shown in Figure 11, is a 3D printed 1:14 scale model of the final SolidWorks design. The prototype provided a visualization for the thickness of the table relative to its length and width. It showed that the thickness will be sufficient relative to the placement of the supports (legs), but that the tabletop thickness will be insufficient to support any of the weight of the clean-room hood. The clean-room hood weight should be placed completely onto the table legs, so a hole was employed through the table, at the ends of the clean room hood and to direct its weight directly to the legs, with no stress supported by the table. These holes are shown in Figure 11.

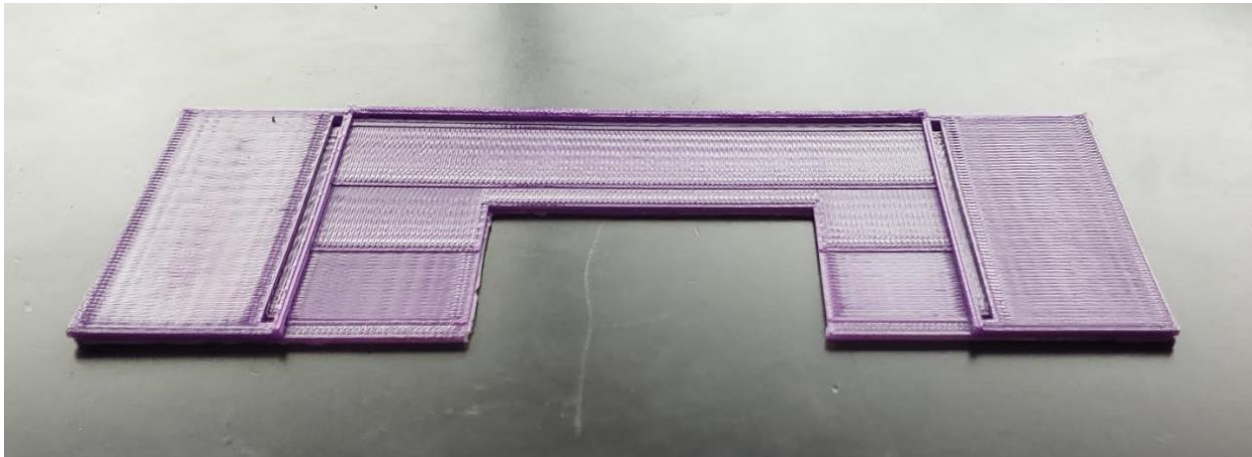

Figure 11: Final Table top Design Prototype

Final Design: Storage

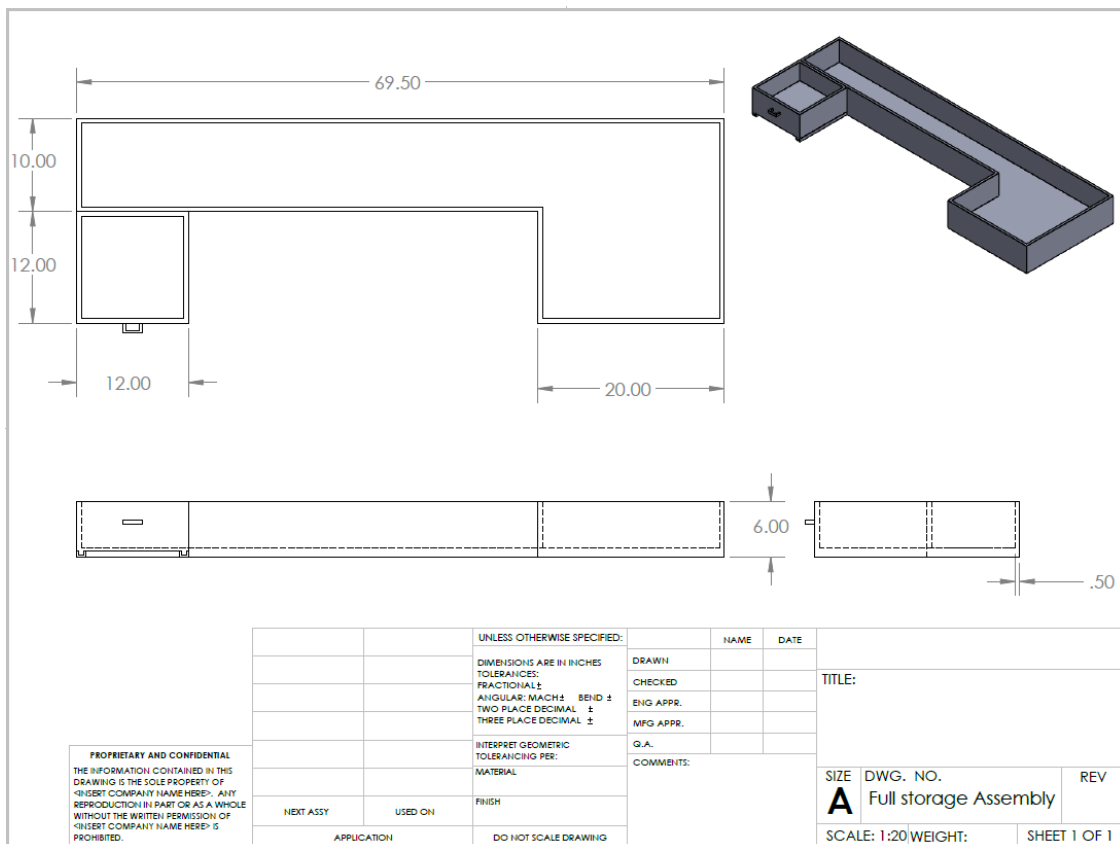

Figure 12: Final Storage SolidWorks Design

Figure 12 depicts the final design for the storage, in inches. The U-shape design was chosen for the storage area, so that the cart could be used as a desk with space for sitting. Moreover, this space is necessary to allow for the x-ray machine to fit directly beneath the workspace for

videography and imaging. The storage area is almost six feet, the length of the table, but the reasons for its specific dimensions were provided by the client for this revision, an update from the Preliminary Report design, shown in Figure 13. A drawer for office supplies, requested by the client, pulls out for accessibility, and is shown in Figure 12 to be 12”x12”, enough area for office supplies. Its width is the distance from the location of the legs to the edge of the tabletop. It would not be appropriate to extend any of the storage area past the dimensions of the tabletop, due to accessibility and safety issues, aesthetics, and to provide a way to attach a laminate film for clean-room effect within the storage area during transport. The height of the back-most area in the L-shape storage shelf, 10” in the figure, is determined by keeping the storage within the confines of the table legs, and the back of the workspace. It is not susceptible to being leaked on if the workspace leaks where it is sealed; this precaution was emphasized by Dr. Becker. Similar precaution is taken for the storage area on the right, the larger portion of the L-shaped area, shown as 20” wide in the figure. It is dimensioned to be placed right of the above tabletop workspace, but is also centered between the right table legs, so that the storage is balanced. The changes from prior revisions include a wider length, to match the tabletop, and a wider storage area on the right side of the L-shape. The storage area has also been dimensioned to regard the tabletop and legs, since the dimensions for the tabletop have been further verified by the client.

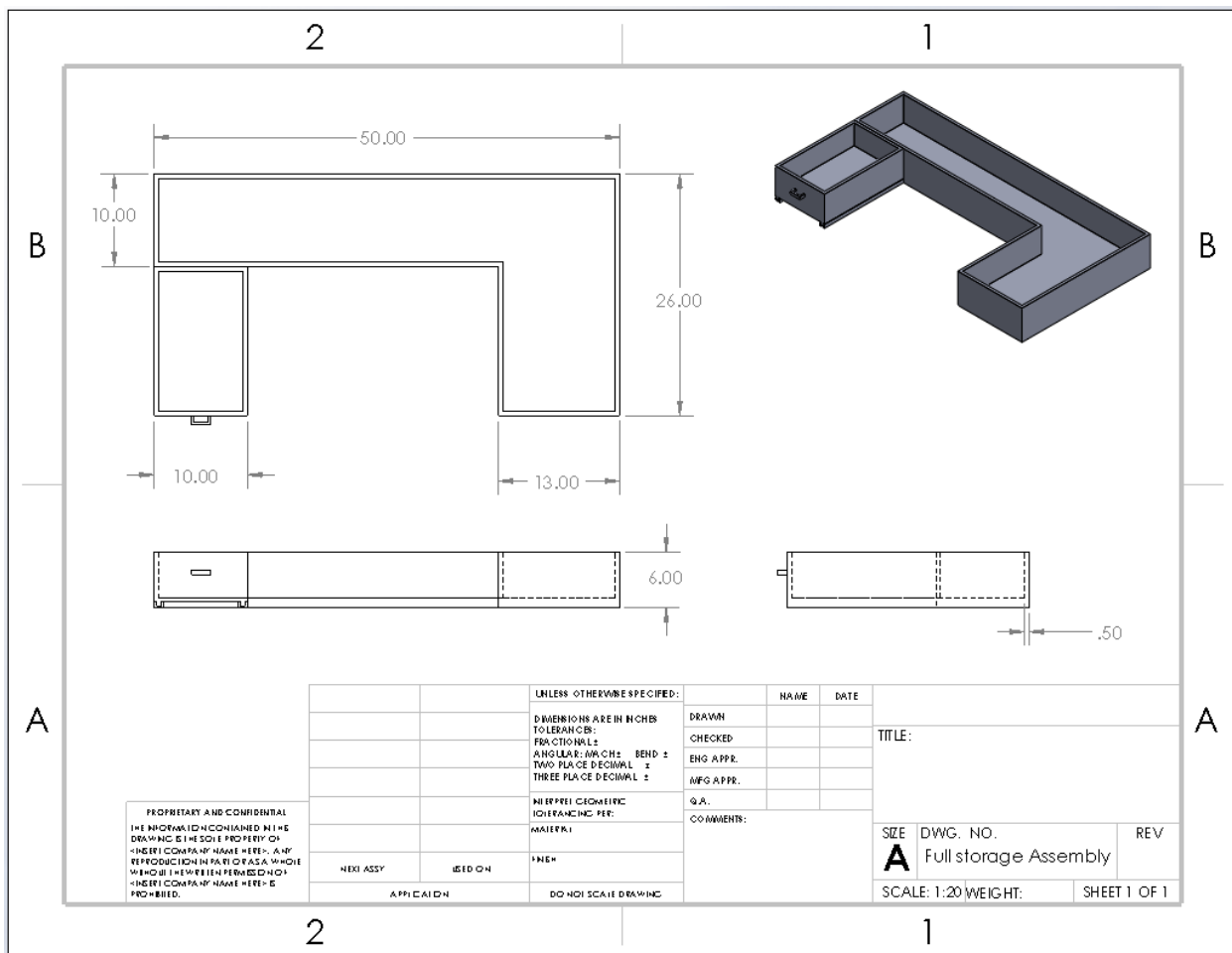

Figure 13: Preliminary Report Storage SolidWorks Design

The storage prototype, shown in Figure 14 below, is a 1:3 scale foam board construction of the final SolidWorks design. Seeing the proportions of the different areas in the storage assembly allowed visualization of what medical devices would be placed in each region. The largest region, the right-most area, will most likely hold the heaviest equipment. Because it will hold the heaviest and largest devices and equipment, that storage area should be balanced between the rightmost legs to allow for balance and equal support.

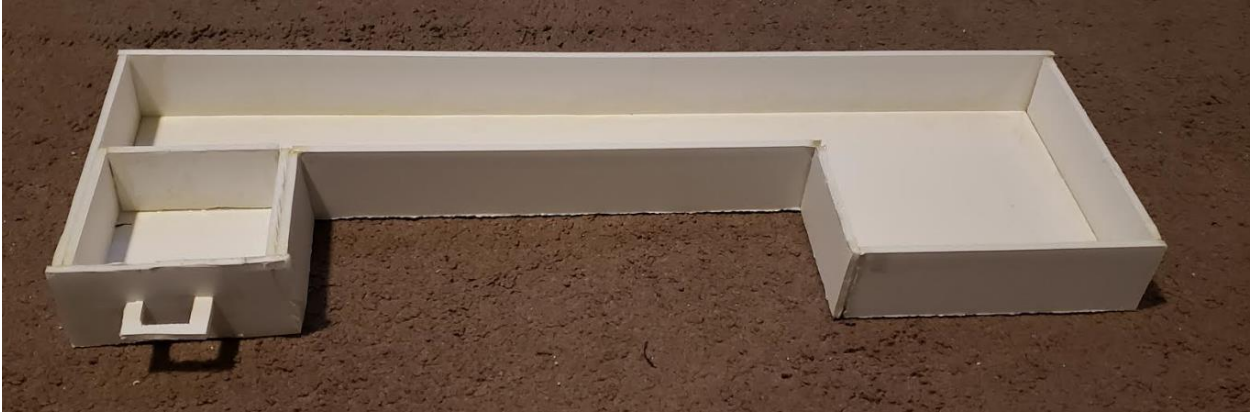

Figure 14: Final Storage Design Prototype

Final Design: Shock Absorption and Full Assembly

Polyurethane foam tires are attached to the bases of the legs for shock absorption. This selection was instructed from the client, and has changed from the suggested pneumatic tires analyzed in the Preliminary Report. The polyurethane foam wheelbarrow tires will not deflate or flatten.

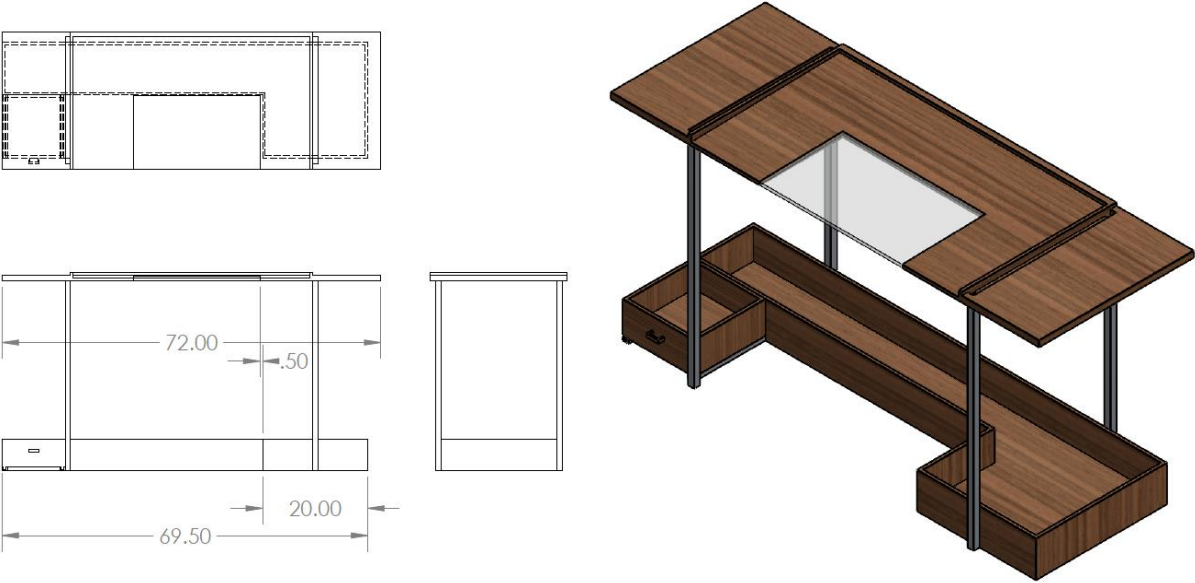

Figure 15: Final Assembly SolidWorks Design

The SolidWorks assembly, shown in Figure 15, depicts the tabletop, with the polycarbonate workspace, fitting together with the storage area and the placement of the table legs. The placement of the table legs is pre-determined by the clean-room hood. The clean-room hood weight will be diverted to the legs, and it reduces the amount of stress on other areas of the tabletop or beams to place the legs directly under the corners of the clean-room hood frame. The aerial view depicts the storage area being separated from the workspace, in case of leakage in the seal. The aerial and front views show that the storage has a shorter length than the tabletop on the right side, but is flush with the tabletop on the left side. The side view shows that the tabletop extends farther than the legs, but that the storage area is contained within the dimensions of the table legs.

## 5.2: Implementation Plan

The implementation plan regarding the portable bench is as follows. The team will be using the machine shop, also at home methods for implementing and bringing the design to life. The team will be getting most of the material required for the design from Home Depot, with a couple things coming from amazon. The breakdown of the full bill of materials for this project can be found in Appendix A. One of the members of our team is planning on getting machine shop certified in order to do some of the building of the portable bench in the machine shop. We will start ordering some materials from Home Depot and Amazon over winter break/early January to ensure that everything gets delivered in time. The tabletop component of this project will be manufactured in house, using mostly a table saw with fasteners with a drill to assemble it. The wood surface will be coated in order to protect it from deforming from spills. The polycarbonate will be attached to the surface using an adhesive. The tabletop part of the design will be the most time-consuming part of manufacturing so this will be done first. We have determined to start building this by February of next year, with expected completion by mid-February. The storage part of the design will also be manufactured in house, using a table saw and drill. This along with the legs and tire assembly will be step two in the implementation plan. We expect to start after the tabletop is finished in mid-February and finish by the beginning of March. This will allow us to assemble everything together by Mid-March, in order to be about a week early for the deadline of having the final product completed by the end of March. After this, testing proof will begin in early April and U-grads will happen at the end of April.



## VI CONCLUSIONS VI

The report describes Anevas Technologies, Inc. and their purpose for contracting a portable medical bench. The client requires a medical research device table that is compatible with x-ray imaging and the respective machine, that can store the devices and support their necessary clean-room hood, as well as successfully transport the apparatus from one building to another with shock absorption. The main requirements are that the portable medical bench is durable, sturdy, reliable, safe, maneuverable during transport, and absorbs shock. The applicable standards and codes are outlined. The testing procedures to ensure the requirements are described for the next semester; testing will take place before, during, and after construction of each part and the full assembly; the most important tests are the frame stress and strain for durability, the tabletop and workspace deflection and rigidity for reliability, the apparatus temperature resistance for safety, and shock absorption. Risk analysis pinpoints focus areas for testing and design; the highest ranked risk analyses involve liquid spills affecting the medical research devices and shock absorption. The final solution and outcome of the semester is an assembly separated into three subsystems: tabletop, storage, and shock absorbing tires. The tabletop and storage are around six feet long, with the workspace and supported clean-room hood centered on the table; there is drainage control to protect the devices, and additional design dimensions for further drainage protection in case of leak or failure; the materials and thicknesses are compatible with x-ray imaging. The storage area is designed so that the bench can be used as a desk and to minimize interference with the x-ray imaging machine; there is maximum storage space with a large, more centrally supported area for heavier devices. The chosen shock absorption, as preferred by the client, is a set of pneumatic tires. The entire assembly will be maneuverable, dimensionally, and strong enough to support the clean room hood, filter, and all devices.

## VIII APPENDICES VIII

### 8.1: Appendix A: Bill of Materials

Part	Material	Quantity	Manufacturer	Cost(total)
Tabletop	Wood	1	Home Depot	\$100.00
Tabletop coating	Wood finish	1	Home Depot	\$10.00
Workspace	Polycarbonate	1	(NAU provided)	\$0.00
Legs	Metal	4	Home Depot	\$40.00
Wheelbarrow Tire	Polyurethane	4	Amazon	\$106.00
Storage Shelf	Wood	1	Home Depot	\$35.00
Drawer	Wood	1	Home Depot	\$20.00
Drawer Slides	Metal/Plastic	2	Home Depot	\$20.00
Drawer Wheels	Metal/Plastic	4	Home Depot	\$10.00
Storage Cover	Polymer	1	Amazon	\$40.00
Handle	Wood	1	Home Depot	\$4.00
Fasteners	Metal	1	Home Depot	\$5.00
Adhesive	Glue	1	Home Depot	\$10.00
				Total: \$400.00